

# REMINGTON®

## WASHUP™ Rotary Shaver



**RC4381AU**

[www.remington-products.com.au](http://www.remington-products.com.au)  
[www.remington.co.nz](http://www.remington.co.nz)

---

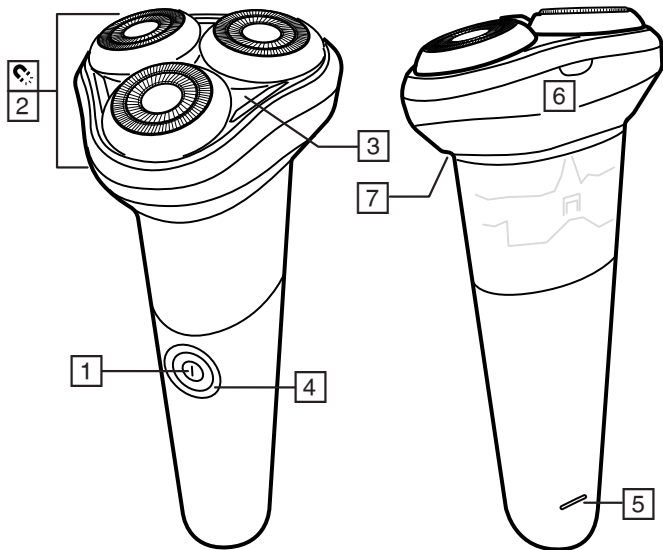



---

## Before First Use

|   |  |
|---|--|
|  | Read the instructions and retain for future reference. |
|---|--|

---

## Intended Use

|   |                                    |
|---|------------------------------------|
|  | Household use only                 |
|  | Suitable for use in bath or shower |

---

## Specification

|                                |       |
|--------------------------------|-------|
| <b>Charge Type</b>             | USB-C |
| <b>Quick Charge Time (min)</b> | 5     |
| <b>Charge Time (min)</b>       | 60    |
| <b>Run time (min)</b>          | 60    |
| <b>IP</b>                      | IPX7  |

---

## Important Safeguards

When using an electrical appliance, basic safety precautions should always be followed to reduce the risk of fire, electric shock, and/or injury, including the following:

- Do not use the appliance for any purpose other than those described in these instructions.
- Do not operate the appliance if it's damaged or malfunctions.
- Do not use accessories or attachments other than those we supply.

- This appliance can be used by children aged from 8 years and above and persons with reduced physical, sensory or mental capabilities or lack of experience and knowledge if they have been supervised/instructed and understand the hazards involved. Children shall not play with the appliance. Cleaning and user maintenance shall not be done by children unless they are older than 8 and supervised. Keep the appliance and cable out of reach of children under 8 years.
- Detach the device from the charging adapter before cleaning it in water.
- Do not use the product with a damaged cord.
- The battery in this device is not replaceable.
- Do not use the appliance if it is damaged or malfunctions.
- This appliance should never be left unattended when plugged into a power outlet, except when charging.
- Do not plug or unplug the appliance with wet hands.
- Do not twist or kink the cable, or wrap it round the appliance.
- Never drop or insert any object into any of the appliance's openings.
- When charging, you must use an external supply unit with an output terminal of 5V & 1A (the measured maximum output power is less than 15W) and meets the requirements of IEC 60335-1 standard.
- The normal temperature range for charging the battery is from 0°C to 45°C.
- Do not expose the appliance or battery to excessive temperatures.
- The battery is a type Li-ion, 750mAh.
- Do not use outdoors or where aerosol (spray) products are being used, or where oxygen is being administered
- Do not use this appliance with damaged or broken tracks, foils or cutters, as injury may occur.

---

## Parts List

|                  |                          |  |
|------------------|--------------------------|--|
| 1                | Power/function switch    |  |
| 2                | Individual flexing heads |  |
| 3                | Hairpocket               |  |
| 4                | Indicator light          |  |
| 5                | USB-C Charging Port      |  |
| 6                | Head release groove      |  |
| 7                | Washout Port             |  |
| <b>Not Shown</b> |                          |  |
| 8                | USB Charging cable       |  |
| 9                | Head Guard               |  |
| 10               | Cleaning Brush           |  |

---

## Charging

- Always ensure that your hands, shaver and mains adaptor are dry before charging.
- Ensure the appliance is switched off.
- Before using the appliance for the first time charge it for 1 hour.
- Your shaver cannot be overcharged. If the product is not going to be used for an extended time period (2-3 months), unplug it from the mains and store.
- To preserve batteries, let them run out every 6 months then recharge for 1 hour.

---

## Charging Status

Charging status is shown:

|   |                 |  |
|---|-----------------|--|
| 4 | Indicator light |  |
|---|-----------------|--|

| Status        | LED State      |
|---------------|----------------|
| Charging      | Flashing       |
| Fully Charged | OFF            |
| In use        | Solid          |
| Low Battery   | Rapid Flashing |

---

## Use - Everyday Shaving

- Switch on

|   |                       |  |
|---|-----------------------|--|
| 1 | Power/function switch |  |
|---|-----------------------|--|

- Hold the shaver at a right angle to your skin and move the shaver against the direction of the hair growth.
- After shaving, switch off shaver.

Note - Before dry shaving, make sure that the area is clean, dry and free from creams or oil.

---

## Travel Lock

Ensure the appliance is switched OFF  
To activate:

| Parts List | Action       | Duration (sec) |
|------------|--------------|----------------|
| 1          | Press + Hold | 3              |

The Indicator Light will flash 3x.

---

To De-activate, repeat process whilst locked.

When locked, the Indicator Light will flash 3x if the Power/function button is pressed.

---

## Rapid Rinse

Turn the appliance upside down and rinse a tap through the:

|   |              |  |
|---|--------------|--|
| 7 | Washout Port |  |
|---|--------------|--|

for daily maintenance that helps prevent build up of dirt and hair

---

## Clean Mode Alert

When the unit is in need of a clean The:

|   |                 |  |
|---|-----------------|--|
| 4 | Indicator light |  |
|---|-----------------|--|

will alternatly flash white & red.

---

## Clean Mode Procedure

Ensure the appliance is switched on To activate.

To enter into clean mode:

| Parts List | Action       | Duration (sec) |
|------------|--------------|----------------|
| 1          | Press + Hold | 3              |

The shaver emits a pulsing sound. The Indicator light flashes white and red alternately.

- Place the shaver head in a basin of water or under a tap.
- The clean cycle stops automatically after 15 seconds.

When the clean cycle is complete: The Indicator Light stops flashing and switches off.

---

## Cautionary Notes

If your skin is easily irritated by shaving, or you suffer from skin allergies, you should test a section of your arm or leg before using the shaver. You can also use it wet with soap, foaming gel, or body wash.

---

## Care and Cleaning

Rinse clean using a damp cloth and dry:

|   |                          |
|---|--------------------------|
| 2 | Individual flexing heads |
| 3 | Hairpocket               |

---

## Battery Removal

This appliance contains batteries that are non-replaceable. When the battery is at the end of its life or leaking, the appliance and battery must be properly disposed of at an official recycling point.

- We strongly recommend that a professional removes the rechargeable battery. Parts of the shaver case, and tools have sharp edges and may cause injury if not handled correctly.
- Be aware of the risk of terminals of the battery being short-circuited by metal objects.
- The rechargeable battery must be removed from the appliance before it is scrapped.
- Disconnect the charging USB cable before removing the battery.
- Discharge the unit and remove the shaver head.
- Use a small flat screwdriver to pry

- 
- away the Bottom Cover from unit bottom
- Unscrew (2s) screws from the unit bottom.
  - Use a small flat screwdriver to pry away the Power Button from unit carefully and remove the Power Button and Button Bracket.
  - Hold the handle, and carefully push the unit bottom, and take the internal assembly out.
  - Unscrew (5s) screws from the internal assembly.
  - Take away the internal assembly cover and expose the printed circuit board.
  - Pry the battery out from internal housing.
  - Expose the battery and cut the connections on battery ends.
  - Used batteries must be removed from the appliance and disposed of at an appropriate official recycling/ collection point.
  - Do not attempt to operate the shaver once you have opened it.
  - Dispose of the battery safely.

---

## Disposal & Recycling

Legislation in some localities mandates that e-waste (anything with a plug, battery or cord) is disposed of through controlled recycling facilities and must not be disposed of in general household waste. For more information about recycling of electrical and battery operated appliances, please contact your local council or your local household waste disposal service.

---

## Warranty against defects

Spectrum Brands Australia Pty Ltd and Spectrum Brands New Zealand Limited  
In this warranty:

**Australian Consumer Law** means the Australian consumer law set out in Schedule 2 to the Competition and Consumer Act 2010;

**CGA** means the New Zealand Consumer Guarantees Act 1993;

**Goods** means the product or equipment which was accompanied by this warranty and purchased in Australia or New Zealand, as the case may be;

**Manufacturer, We or us** means:

1. for Goods purchased in Australia, Spectrum Brands Australia Pty Ltd ACN, 007 070 573; or
2. for Goods purchased in New Zealand, Spectrum Brands New Zealand Limited, as the case may be, contact details as set out at the end of this warranty;

**Supplier** means the authorised distributor or retailer of the Goods that sold you the Goods in Australia or in New Zealand; and

**You** means you, the original end-user purchaser of the Goods.

1. Our goods come with guarantees that cannot be excluded under the Australian Consumer Law, or the CGA. You are entitled to a replacement or refund for a major failure and compensation for any other reasonably foreseeable loss or damage. You are also entitled to have the goods repaired or replaced if the goods fail to be of acceptable quality and the failure does not amount to a major failure.
2. The benefits provided by this Warranty are in addition to all other rights and remedies in respect of the Goods which the consumer has under either the Australian Consumer Law or the CGA. The original purchaser of the Goods is provided with the following Warranty subject to the Warranty

---

Conditions:

3. We warrant the Goods for all parts defective in workmanship or materials for the period of three (3) years from the date of purchase (**Warranty Period**). If the Goods prove defective within the Warranty Period by reason of improper workmanship or material, we may, at our own discretion, repair or replace the Goods without charge.

---

## Warranty Conditions

4. The Goods must be used in accordance with the manufacturer's instructions. This Warranty does not apply should the defect in or failure of the Goods be attributable to misuse, abuse, accident or non-observance of manufacturer's instructions on the part of the user. As far as the law permits, the manufacturer does not accept liability for any direct or consequential loss, damage or other expense caused by or arising out of any failure to use the Goods in accordance with the manufacturer's instructions.
5. Consumable parts (such as shaver heads, cutters and foils) of the Goods are included under this Warranty only where there is a defect in workmanship or materials used.
6. The warranty granted under clause 3 is limited to repair or replacement only.
7. Any parts of the Goods replaced during repairs or any product replaced remain the property of the manufacturer. In the event of the Goods being replaced during the Warranty Period, the warranty on the replacement Goods will expire on the same date as for the Warranty Period on the original Goods which are replaced.
8. In order to claim under the warranty granted under clause 3 you must:
  - (a) Retain this warranty with your receipt/proof of purchase; and
  - (b) Return the Goods to us at the relevant address below or to the Supplier by prepaid freight within the Warranty Period accompanied with (i) the legible and unmodified original proof of purchase, which clearly indicates the name and address of the Supplier, the date and place of purchase, the product name or other product serial number and (ii) this warranty.
9. This warranty is immediately void if:
  - (a) Any serial number or appliance plate is removed or defaced;
  - (b) The Goods have been serviced or otherwise repaired by a person not authorised to do so by us or where non approved replaced parts are used.
10. The Goods are designed for domestic use only. A limited 90-day Warranty applies to any industrial or commercial use of the Goods. The Goods must be connected to the electrical voltage requirements as specified in the ratings label located on the Goods.
11. This warranty does not cover the cost of claiming under the warranty or transport of the Goods to and from the Supplier or us.
12. This warranty is only valid and enforceable in Australia against Spectrum Brands Australia Pty Ltd and in New Zealand against Spectrum Brands New Zealand Limited.

---

## **Service Centre**

### **AU**

Spectrum Brands Australia Pty Ltd  
Locked Bag 3004  
Braeside, VIC 3195  
AUSTRALIA  
Customer service in Australia: 1800  
623 118  
E-mail: [consumer.enquiry@remington-  
products.com.au](mailto:consumer.enquiry@remington-products.com.au)  
Website: [www.remington-products.  
com.au](http://www.remington-products.com.au)

### **NZ**

Spectrum Brands New Zealand Limited  
PO Box 9817  
Newmarket, Auckland 1149  
NEW ZEALAND  
Customer service in New Zealand: 0800  
736 776  
E-mail: [info@remington.co.nz](mailto:info@remington.co.nz)  
Website: [www.remington.co.nz](http://www.remington.co.nz)

---

---

---

**Ref. No. RC4381AU**

**Type No. R38A**

26/AU/ RC4381AU

T22-0005755

Version 01 /26

Remington® is a Registered Trade Mark  
of Spectrum Brands, Inc., or one of its  
subsidiaries.

© 2026 Spectrum Brands, Inc.

---